

TB-2705 PXI™ TERMINAL BLOCK FOR E SERIES AND WAVEFORM GENERATION DEVICES

This installation guide describes how to install and connect signals to the TB-2705 terminal block for use with PXI E Series and waveform generation devices.

Introduction

The TB-2705 is a terminal block assembly consisting of a printed circuit board, 62 screw terminals, and a plastic enclosure with a strain relief. The terminal block assembly connects directly to the front panel of National Instruments E Series and waveform generation devices, eliminating the need for an external cable.

The TB-2705 allows you to easily connect analog input, analog output, counter-timer, and digital I/O signals to your National Instruments device. The 62 screw terminals allow access to every pin on the device with the exception of some digital ground signals that are common to one another. The TB-2705 also has a shielded strain-relief to secure your I/O wires and provide an adequate chassis-ground connection.

What You Need to Get Started

You need the following to set up and use your terminal block:

- TB-2705 Terminal Block Assembly
- TB-2705 PXI Terminal Block for E Series and Waveform Generation Devices Installation Guide*
- One of the following:
 - PXI E Series device
 - waveform generation device with a 68-pin I/O connector

- One of the following:
 - *PXI E Series User Manual*
 - waveform generation device user manual
- 0.10 in. slotted screwdriver
- Number 1 Phillips-head screwdriver
- Wire cutters
- Wire insulation stripper
- One of the following:
 - E Series device overlay
 - Waveform generation device overlay

Conventions

The following conventions are used in this guide:

<>

Angle brackets that contain numbers separated by an ellipsis represent a range of values associated with a bit or signal name—for example, DBIO<3..0>.



This icon denotes a note, which alerts you to important information.



This icon denotes a caution, which advises you of precautions to take to avoid injury, data loss, or a system crash.

italic

Italic text denotes variables, emphasis, a cross reference, or an introduction to a key concept. This font also denotes text that is a placeholder for a word or value that you must supply.

Safety Information



Cautions Do *not* operate the device in an explosive atmosphere or where there may be flammable gases or fumes.

Do *not* operate damaged equipment. The safety protection features built into this device can become impaired if the device becomes damaged in any way. If the device is damaged, turn the device off and do *not* use it until service-trained personnel can check its safety. If necessary, return the device to National Instruments for service and repair to ensure that its safety is not compromised.

Do *not* operate this equipment in a manner that contradicts the information specified in this document. Misuse of this equipment could result in a shock hazard.

Do *not* substitute parts or modify equipment. Because of the danger of introducing additional hazards, do *not* install unauthorized parts or modify the device. Return the device to National Instruments for service and repair to ensure that its safety features are not compromised.

You *must* insulate all of your signal connections to the highest voltage with which the TB-2705 can come in contact.

Connections, including power signals to ground and vice versa, that exceed any of the maximum signal ratings on the terminal block can create a shock or fire hazard, or can damage any or all of the boards connected to the host computer, and the terminal block. National Instruments is *not* liable for any damages or injuries resulting from incorrect signal connections.

Clean the module and accessories by brushing off light dust with a soft non-metallic brush. Remove other contaminants with a stiff non-metallic brush. The unit *must* be completely dry and free from contaminants before returning it to service.

Signal Descriptions

Table 1 describes the E Series signals available on the TB-2705. Table 2 describes the waveform generation signals.

Table 1. TB-2705 Terminal Block E Series Signal Descriptions

Signal Name	Reference	Direction	Description
AIGND	—	—	Analog Input Ground—These terminals are the reference point for single-ended measurements in RSE configuration and the bias current return point for differential measurements. All three ground references—AIGND, AOGND, and DGND—are connected together on your E Series device.
ACH<0..15>	AIGND	Input	Analog Input Channels 0 through 15—You can configure each channel pair, ACH< <i>i</i> , <i>i</i> +8> (<i>i</i> = 0..7), as either one differential input or two single-ended inputs.

Table 1. TB-2705 Terminal Block E Series Signal Descriptions (Continued)

Signal Name	Reference	Direction	Description
AISENSE	AIGND	Input	Analog Input Sense—This terminal serves as the reference node for any of channels ACH <0..15> in NRSE configuration.
DAC0OUT	AOGND	Output	Analog Channel 0 Output—This terminal supplies the voltage output of analog output channel 0.
DAC1OUT	AOGND	Output	Analog Channel 1 Output—This terminal supplies the voltage output of analog output channel 1.
EXTREF	AOGND	Input	External Reference—This terminal is the external reference input for the analog output circuitry.
AOGND	—	—	Analog Output Ground—The analog output voltages are referenced to these terminals. All three ground references—AIGND, AOGND, and DGND—are connected together on your E Series device.
DGND	—	—	Digital Ground—These pins supply the reference for the digital signals at the I/O connector as well as the +5 VDC supply. All three ground references—AIGND, AOGND, and DGND—are connected together on your E Series device.
DIO<0..7>	DGND	Input or Output	Digital I/O Signals—DIO 6 and 7 can control the up/down signal of general-purpose counters 0 and 1, respectively.
+5 V	DGND	Output	+5 VDC Source—These terminals are fused for up to 1 A of +5 V supply. The fuse is self-resetting.

Table 1. TB-2705 Terminal Block E Series Signal Descriptions (Continued)

Signal Name	Reference	Direction	Description
SCANCLK	DGND	Output	Scan Clock—This terminal pulses once for each A/D conversion in the scanning modes when enabled. The low-to-high edge indicates when you can remove the input signal from the input or switched to another signal.
EXTSTROBE	DGND	Output	External Strobe—This output is used for controlling SCXI modules.
PFI0/TRIG1	DGND	Input	PFI0/Trigger 1—As an input, this is either one of the programmable function inputs (PFIs) or the source for the hardware analog trigger. For more information on PFI signals, see the <i>PXI E Series User Manual</i> .
		Output	As an output, this is the TRIG1 signal. In posttrigger data acquisition sequences, a low-to-high transition indicates the initiation of the acquisition sequence. In pretrigger applications, a low-to-high transition indicates the initiation of the pretrigger conversions.
PFI1/TRIG2	DGND	Input	PFI1/Trigger 2—As an input, this is one of the PFIs.
		Output	As an output, this is the TRIG2 signal. In pretrigger applications, a low-to-high transition indicates the initiation of the posttrigger conversions. TRIG2 is not used in posttrigger applications.
PFI2/CONVERT	DGND	Input	PFI2/Convert—As an input, this is one of the PFIs.
		Output	As an output, this is the CONVERT* signal. A high-to-low edge on CONVERT* indicates the start of an A/D conversion.

Table 1. TB-2705 Terminal Block E Series Signal Descriptions (Continued)

Signal Name	Reference	Direction	Description
PFI3/GPCTR1_SOURCE	DGND	Input	PFI3/Counter 1 Source—As an input, this is one of the PFIs.
		Output	As an output, this is the GPCTR1_SOURCE signal. This signal reflects the actual source connected to general-purpose counter 1.
PFI4/GPCTR1_GATE	DGND	Input	PFI4/Counter 1 Gate—As an input, this is one of the PFIs.
		Output	As an output, this is the GPCTR1_GATE signal. This signal reflects the actual gate signal connected to the general-purpose counter 1.
GPCTR1_OUT	DGND	Output	Counter 1 Output—This is the general-purpose counter 1 output.
PFI5/UPDATE	DGND	Input	PFI5/Update—As an input, this is one of the PFIs.
		Output	As an output, this is the UPDATE* signal. A high-to-low edge on UPDATE* indicates that the analog output primary group is updating.
PFI6/WFTRIG	DGND	Input	PFI6/Waveform Trigger—As an input, this is one of the PFIs.
		Output	As an output, this is the WFTRIG signal. In timed analog output sequences, a low-to-high transition indicates the initiation of the waveform generation.
PFI7/STARTSCAN	DGND	Input	PFI7/Start of Scan—As an input, this is one of the PFIs.
		Output	As an output, this is the STARTSCAN signal. This pin pulses once at the start of each analog input scan in the interval scan. A low-to-high transition indicates the start of the scan.

Table 1. TB-2705 Terminal Block E Series Signal Descriptions (Continued)

Signal Name	Reference	Direction	Description
PFI8/GPCTR0_SOURCE	DGND	Input	PFI8/Counter 0 Source—As an input, this is one of the PFIs.
		Output	As an output, this is the GPCTR0_SOURCE signal. This signal reflects the actual source connected to the general-purpose counter 0.
PFI9/GPCTR0_GATE	DGND	Input	PFI9/Counter 0 Gate—As an input, this is one of the PFIs.
		Output	As an output, this is the GPCTR0_GATE signal. This signal reflects the actual gate signal connected to the general-purpose counter 0.
GPCTR0_OUT	DGND	Output	Counter 0 Output—This is the general-purpose counter 0 output.
FREQ_OUT	DGND	Output	Frequency Output—This output is from the frequency generator output.

Table 2. TB-2705 Terminal Block Waveform Generation Signal Descriptions

Signal Name	Reference	Direction	Description
AOGND	—	—	Analog Output Ground—The analog output voltages are referenced to this node.
DAC<0..7>OUT	AOGND	Output	Analog Output Channels 0 through 7—These pins supply the voltage output of the respective channel.
DGND	—	—	Digital Ground—This pin supplies the reference for the digital signals at the I/O connector as well as the reference for the +5 VDC supply.
DIO<0..7>	DGND	Input or Output	Digital I/O Signals—DIO6 and 7 can control the up/down signal of general-purpose counters 0 and 1, respectively.

Table 2. TB-2705 Terminal Block Waveform Generation Signal Descriptions (Continued)

Signal Name	Reference	Direction	Description
+5 V	DGND	Output	+5 VDC Source—These pins are fused for up to 1 A of +5 V supply. The fuse is self-resetting.
EXTREF	AOGND	Input	External Reference—This is the external reference input for the analog output circuitry.
EXTSTROBE*	DGND	Output	External Strobe—This output is used for controlling SCXI modules.
PFI0	DGND	Input	PFI0—As an input, this is one of the Programmable Function Inputs (PFIs). For more information on PFI signals, see the <i>6711/6713/6715 User Manual</i> . You cannot use PFI0 as an output.
PFI1	DGND	Input	PFI1—As an input, this is one of the PFIs. You cannot use PFI1 as an output.
PFI2	DGND	Input	PFI2—As an input, this is one of the PFIs. You cannot use PFI2 as an output.
PFI3/GPCTR1_SOURCE	DGND	Input	PFI3/Counter 1 Source—As an input, this is one of the PFIs.
		Output	As an output, this is the GPCTR1_SOURCE signal. This signal reflects the actual source connected to the general-purpose counter 1.
PFI4/GPCTR1_GATE	DGND	Input	PFI4/Counter 1 Gate—As an input, this is one of the PFIs.
		Output	As an output, this is the GPCTR1_GATE signal. This signal reflects the actual gate signal connected to the general-purpose counter 1.
GPCTR1_OUT	DGND	Output	Counter 1 Output—This is the general-purpose counter 1 output.

Table 2. TB-2705 Terminal Block Waveform Generation Signal Descriptions (Continued)

Signal Name	Reference	Direction	Description
PFI5/UPDATE*	DGND	Input	PFI5/Update—As an input, this is one of the PFIs.
		Output	As an output, this is the UPDATE* signal. A high-to-low edge on UPDATE* indicates that the analog output waveform generation group is being updated.
PFI6/WFTRIG	DGND	Input	PFI6/Waveform Trigger—As an input, this is one of the PFIs.
		Output	As an output, this is the WFTRIG signal. In timed analog output sequences, a low-to-high transition indicates the initiation of the waveform generation.
PFI7	DGND	Input	PFI7—As an input, this is one of the PFIs. You cannot use PFI7 as an output.
PFI8/GPCTR0_SOURCE	DGND	Input	PFI8/Counter 0 Source—As an input, this is one of the PFIs.
		Output	As an output, this is the GPCTR0_SOURCE signal. This signal reflects the actual source connected to the general-purpose counter 0.
PFI9/GPCTR0_GATE	DGND	Input	PFI9/Counter 0 Gate—As an input, this is one of the PFIs.
		Output	As an output, this is the GPCTR0_GATE signal. This signal reflects the actual gate signal connected to the general-purpose counter 0.
GPCTR0_OUT	DGND	Output	Counter 0 Output—This is the general-purpose counter 0 output.
FREQ_OUT	DGND	Output	Frequency Output—This is the frequency generator output.

Connecting the Signals

See your *PXI E Series User Manual* or waveform generation device user manual for examples of how to connect your signals. Refer to Figure 1 as you perform the following steps to connect signals to your terminal block.

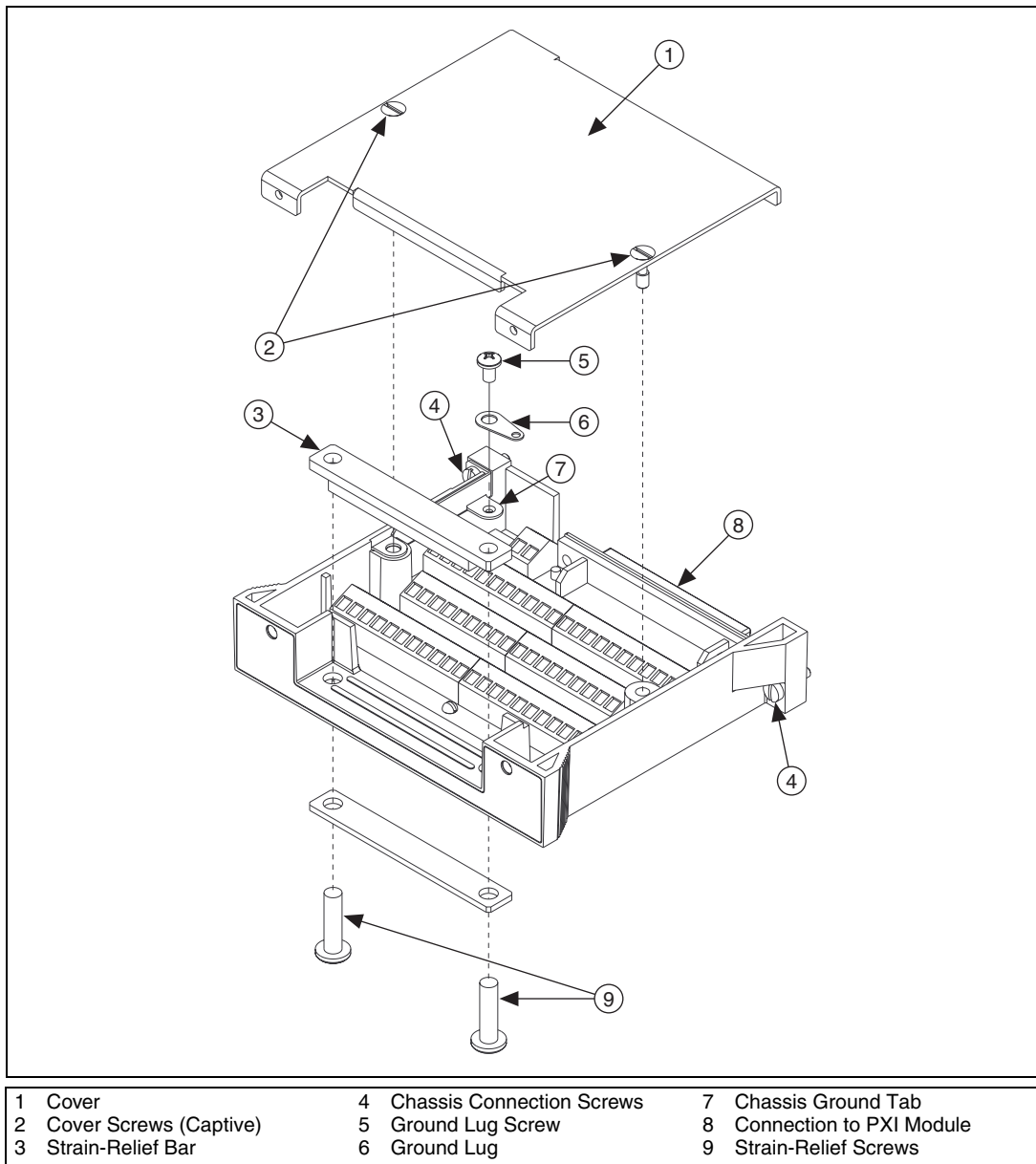

Figure 1. TB-2705 Parts Locator Diagram

1. Remove the terminal block cover by unscrewing the two cover screws using the 0.10 in. slotted screwdriver.



Note Your kit contains overlays for both E Series and waveform generation devices. Use the appropriate overlay for your application.

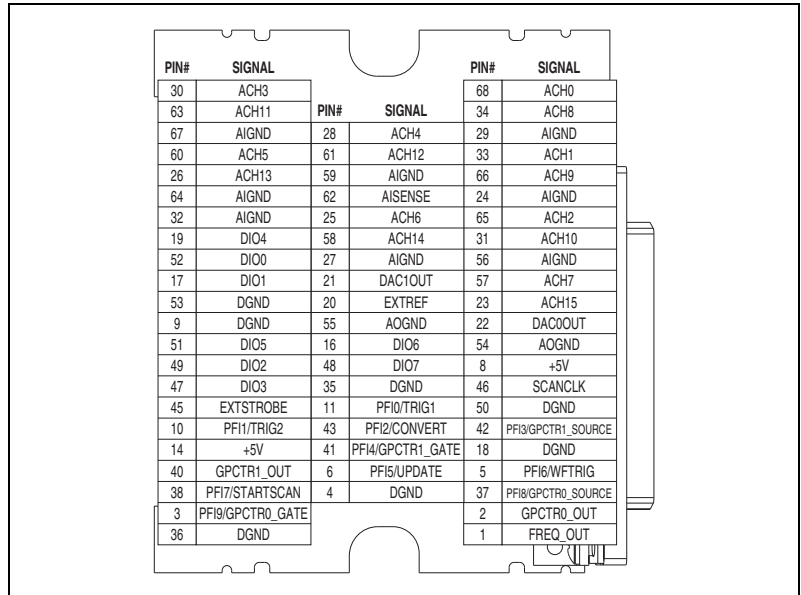

Figure 2. E Series Device Overlay

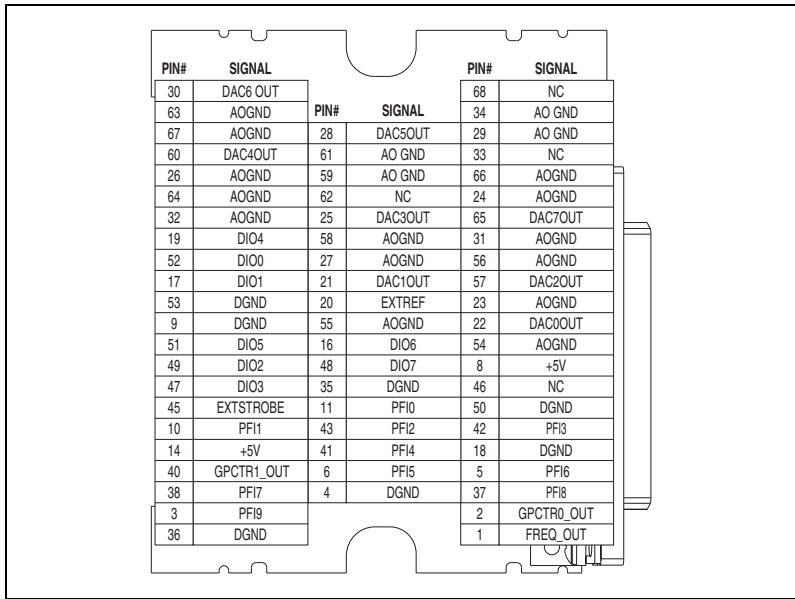

Figure 3. Waveform Generation Device Overlay

- Apply the label to the inside of the top cover as shown in Figure 4. This label is a pin number to signal name reference. Each overlay has an adhesive backing for adhering the overlay to the top cover.

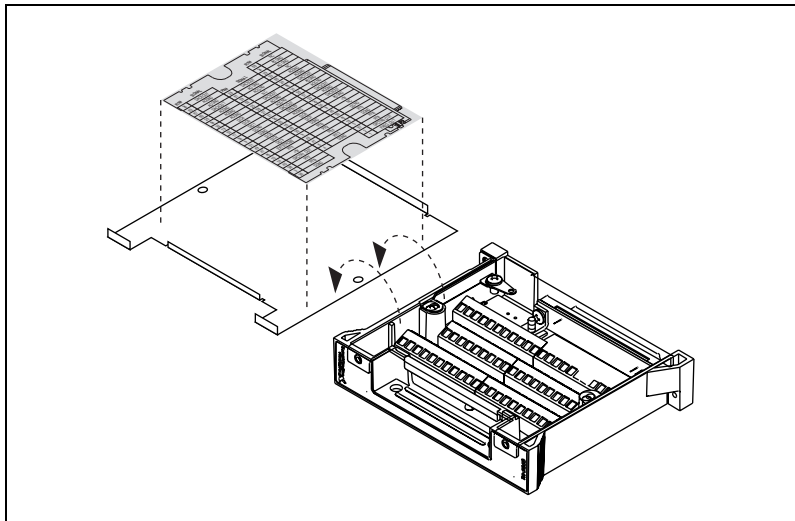

Figure 4. Applying the Overlay

3. Loosen or remove the strain-relief bar by loosening the two strain-relief screws.
4. Use wire cutters and wire insulation strippers to strip no more than 7 mm of insulation from the wire ends.
5. Loosen the screws in the screw terminals with the 0.10 in. slotted screwdriver.
6. Insert the stripped wires into the screw terminals. Tighten the screws with the 0.10 in. slotted screwdriver. No bare wire should extend past the screw terminal. Exposed wire increases the risk of short circuits and failures.
7. Tighten or replace the strain-relief screws.
8. Replace the terminal block cover and tighten the cover screws.

Installing the Terminal Block

Refer to Figure 5 as you perform the following steps to connect the terminal block to the PXI module I/O connector.



Caution The connectors of both the PXI module and the terminal block are polarized. You can attach them in only one way. Do *not* force the terminal block when inserting it into or removing it from the PXI module I/O connector.

1. Install the PXI module into the chassis and tighten the two module screws. You *must* install the TB-2705 terminal block on the PXI module after the module is installed in the chassis.
2. Guide the terminal block onto the switch module connector.
3. Tighten the two terminal block mounting screws.

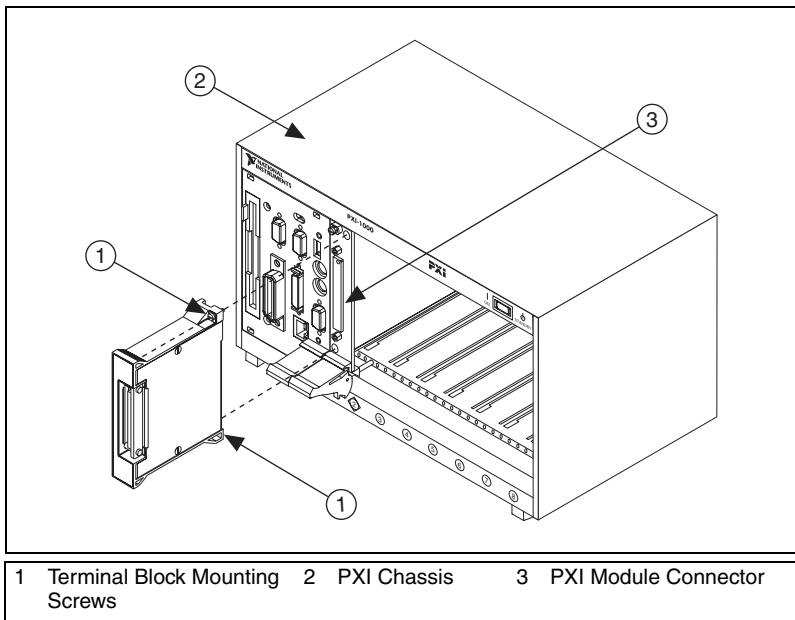

Figure 5. Connecting the TB-2705 to an E Series or Waveform Generation Device



Caution The TB-2705 is not designed for input voltages greater than 42 V, even if you install a voltage divider that reduces the voltage to within the input range of the DAQ device. Input voltages greater than 42 V can damage the TB-2705, any device connected to it, and the host computer. Overvoltage can also cause an electric shock hazard for the operator. National Instruments is *not* liable for damage or injury resulting from such misuse.

Specifications

This section lists the specifications of the TB-2705. These specifications are typical at 25 °C unless otherwise specified.

Input/Output

See the documentation of your E Series or waveform generation device to determine the input/output specifications for your application.

Physical

Dimensions.....	8.4 by 10.7 by 2.0 cm (7.5 by 4.125 by 1.38 in.)
I/O connector.....	One 68-position female connector

Environment

Operating temperature.....	0 to 50 °C
Storage temperature.....	-20 to 70 °C
Relative humidity.....	10 to 90% noncondensing

Safety

Designed in accordance with IEC61010-01, EN 61010-1, UL 3111-1, and CAN/CSA C22.2 No.1010.1 for electrical measuring and testing equipment.

For use at altitudes up to 2000 meters.

Installation Category II

Pollution Degree 2

Electromagnetic Compatibility

EMC/EMI.....	CE, C-Tick and FCC Part 15 (Class A) Compliant
Electrical emissions.....	EN 55011 Class A @ 10 meters FCC Part 15A above 1 GHz
Electrical immunity	Evaluated to EN 61326:1998, Table 1



Note To ensure full EMC and EMI compliance only operate equipment under test (EUT) with shielded cabling. See the Declaration of Conformity for this product for any additional regulatory compliance information.

Technical Support Resources

NI Web Support

National Instruments Web support is your first stop for help in solving installation, configuration, and application problems and questions. Online problem-solving and diagnostic resources include frequently asked questions, knowledge bases, product-specific troubleshooting wizards, manuals, drivers, software updates, and more. Web support is available through the Technical Support section of ni.com

Worldwide Support

National Instruments has offices located around the world to help address your support needs. You can access our branch office Web sites from the Worldwide Offices section of ni.com. Branch office Web sites provide up-to-date contact information, support phone numbers, e-mail addresses, and current events.

If you have searched the technical support resources on our Web site and still cannot find the answers you need, contact your local office or National Instruments corporate. For telephone support in the United States, dial 512 795 8248. For telephone support outside the United States, contact your local branch office:

Australia 03 9879 5166, Austria 0662 45 79 90 0, Belgium 02 757 00 20,
Brazil 011 284 5011, Canada (Calgary) 403 274 9391,
Canada (Ontario) 905 785 0085, Canada (Québec) 514 694 8521,
China 0755 3904939, Denmark 45 76 26 00, Finland 09 725 725 11,
France 01 48 14 24 24, Germany 089 741 31 30, Greece 30 1 42 96 427,
Hong Kong 2645 3186, India 91805275406,
Israel 03 6120092, Italy 02 413091, Japan 03 5472 2970,
Korea 02 596 7456, Mexico (D.F.) 5 280 7625,
Mexico (Monterrey) 8 357 7695, Netherlands 0348 433466,
New Zealand 09 914 0488, Norway 32 27 73 00, Poland 0 22 528 94 06,
Portugal 351 1 726 9011, Singapore 2265886, Spain 91 640 0085,
Sweden 08 587 895 00, Switzerland 056 200 51 51,
Taiwan 02 2528 7227, United Kingdom 01635 523545

